



SENZA

EXTERNAL WARNING DEVICE

- Modern design
- Engineer Hold-off
- Selectable sound output 105dB(A) or 85dB(A)
- Optional trigger wire monitoring
- Selectable timers
- Selectable Negative or Positive triggers
- Confirmation Input
- Fault Output
- Test Input
- Backlight option
- Available in Grade 2, Grade 3 or Wire-free (G2 only)

INSTALLATION AND OPERATING INSTRUCTIONS

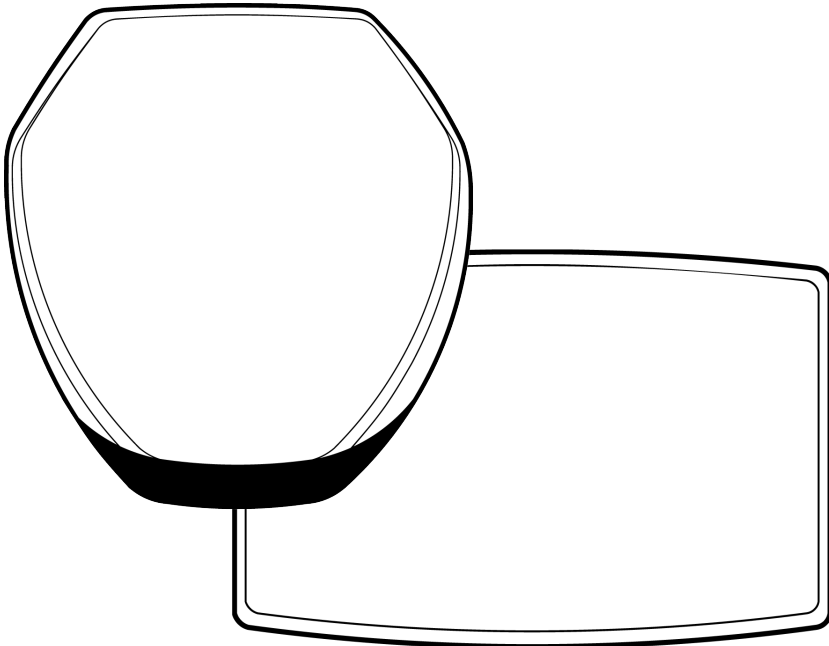

INDEX

- 3 DESCRIPTION**
- 3 FEATURES & OPTIONS**
- 4 LOCATION OF PARTS**
- 5 WIRED PCB LAYOUTS**
- 6 WIRE-FREE PCB LAYOUTS**
- 7 TERMINAL DESCRIPTION**
- 7 DIP SWITCH SETTINGS**
- 8 MOUNTING INSTRUCTIONS**
- 10 WIRING CONNECTION GUIDE** Standard Version
- 11 WIRING CONNECTION GUIDE** PLUS Version
- 12 WIRING CONNECTION GUIDE** Wirefree Version
- 13 FITTING COVERS**
- 14 OPERATING INSTRUCTIONS**
- 15 SPECIFICATION**
- 16 SAFETY PRECAUTIONS**
- 16 PRODUCT ORDER CODES**

DESCRIPTION

This range of external warning devices includes 3 models: 2 wired at Grade 2 & 3 and 1 wire-free at Grade 2 all are Environmental class IV and can be installed in security systems in accordance with EN50131-1: 2006 + A3: 2020. The wired models comply to EN50131-4: 2019, WD type Z; the wire-free model complies to EN50131-4:2019, WD type W. These warning devices feature one piezo and one LED strobe for audible and visual indication of an alarm activation. Each model includes the latest innovation in electronics and incorporates a lithium Ion battery for better reliability, each of the wired versions incorporates a smart charging circuit to optimise the battery capability and battery life. A number of other unique features are listed below.

FEATURES & OPTIONS

Engineer Hold-off

During the first installation of the Senza this feature allows you to connect the on-board battery without the sounder sounding, after hold-off voltage is applied the Senza will enter its normal mode. If Hold-off voltage is removed the sounder will sound.

Back-light

Only available on the PLUS version.

It is possible to select either ON or **ECO (default)**. In the ON position the back-light is permanently ON. In the ECO position the inbuilt light sensor will automatically switch the back-light off during the day, thereby reducing power consumption.

Confirmation

Only available on the PLUS and WIRE-FREE versions.

This feature allows the user to be notified before entering the premises that the intruder alarm system has generated a confirmed alarm due to 2 or more detectors being activated.

During an alarm activation if a negative (0v) signal is applied to the confirmed input at the same time as a signal is applied to the siren input the siren tone will change to a rapid tone every few seconds. If a signal is applied to the strobe input, the strobe flash rate will also change. If the signal is removed from the confirmed input, the tone/flash rate will revert back to the standard tone/flash rate.

If the signal is removed from the siren/strobe inputs the sounder will stop sounding/flushing regardless of a signal being applied to the confirmed input.

Test

Only available on the PLUS and WIRE-FREE versions.

If a positive signal is applied to this input it will start the test routine. At the start of the test the fault output terminals will go open circuit. During the test the siren will sound for 3 seconds, strobe will flash for 3 seconds and battery will be tested to ensure that all are functioning correctly. At the end of a successful test the Senza will make a low level sound and the fault output terminals will change to a closed circuit.

If a fault is detected, the fault output terminals will stay open circuit until the fault has been rectified.

Trigger Monitoring

Only available on the PLUS version and is mandatory for all grade 3 installations.

When selected, the device monitors the siren and strobe trigger wire's integrity by means of monitoring resistors. These resistors are connected to the opposite signal that is required to activate the siren or strobe i.e. negative siren trigger signal (default), the monitoring resistor is connected between a positive and the trigger wire in the control panel. In the event of the siren trigger wire being cut or removed, the fault output circuit will open. In the event of the strobe trigger wire being cut or removed the strobe will start to flash. The fault output circuit will NOT be activated.

Note:- Fitting the resistor in the warning device does not comply with grade 3 requirements.

Fault

Only available on the PLUS and WIRE-FREE versions.

The 2 fault outputs are normally closed and will switch to an open circuit if a fault occurs with the sounder, strobe, and battery. If trigger wire monitoring has been selected the fault output will also open circuit if a fault is detected. It also acts as confirmation that the test procedure has been started by going open circuit and on a successful completion of the test procedure the outputs will go closed circuit.

Volume

Each model will allow you to select the dB(A) level required to comply with the country/regional requirements it is possible to reduce the sound output from 105dB(A) (**default**) to maximum sound output of 85dB(A)

SAB/SCB

Only available on the PLUS versions.

In SAB mode (**default**) the power required to produce the sound is drawn from the security systems control panel. In SCB mode the power required to produce the sound is drawn from the on-board lithium Ion battery.

Siren Cut-off timer

It is possible to select 1 of 3 optional times depending on the model being used

The PLUS version and the WIRE-FREE version have either 15minutes (**default**) 3 minutes or intermittent (50sec ON, 50sec OFF, 50sec ON, 50sec OFF, 50sec ON then stops (times are approximate).

The STANDARD model only has 15minutes (**default**) or intermittent.

Trigger Signal

Each model allows you to select the triggering method used to activate the siren and strobe, either Negative 0v applied (**default**) or positive +ve applied, depending on the output of the control panel you are using.

Tamper Return

Only available on the PLUS and WIRE-FREE versions.

Allows you to select either a Negative signal (**default**) or a positive signal for the Tamper Return signal to match the requirements of the control panel being used.

Strobe Saver

After 1 hour of continuous activation the strobe flash rate will be reduced from 1Hz to 0.25Hz

Communication confirmation

WIRE-FREE version Only

During the installation of the Wire-free version it is possible to check that the best location is selected for the warning device. Whilst in engineer mode the Green LED will flash to indicate that the warning device is communicating with the control panel module, if the Green LED stops flashing this indicates that it has lost communication with the control panel module. Relocate the warning device until the Green LED starts to flash, this indicates that communication have been re-established.

LOCATION OF PARTS

1	Key slot mounting hole
2	Spirit level
3	Tamper protection
4	Swivel Mounting hole
5	Comfort LED
6	Strobe LED
7	Cover fixing screw
8	Cover to electronics
9	Cable entry
10	Piezo
11	Hinge bracket for cover

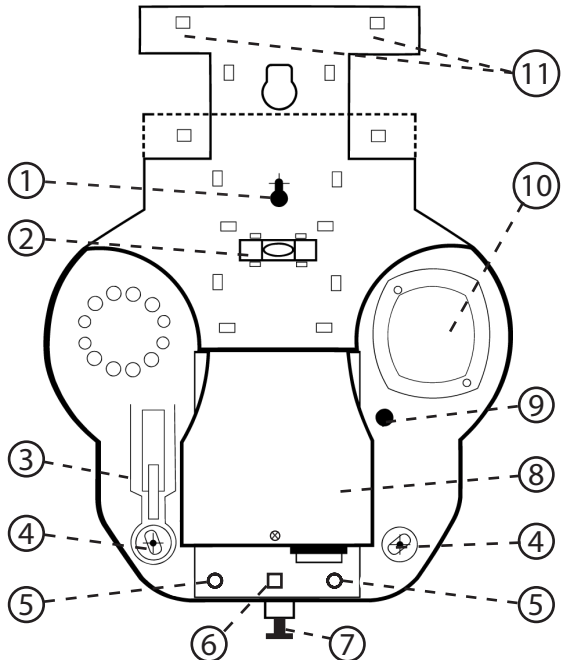

WIRED PCB LAYOUTS

PLUS GRADE 2 & 3

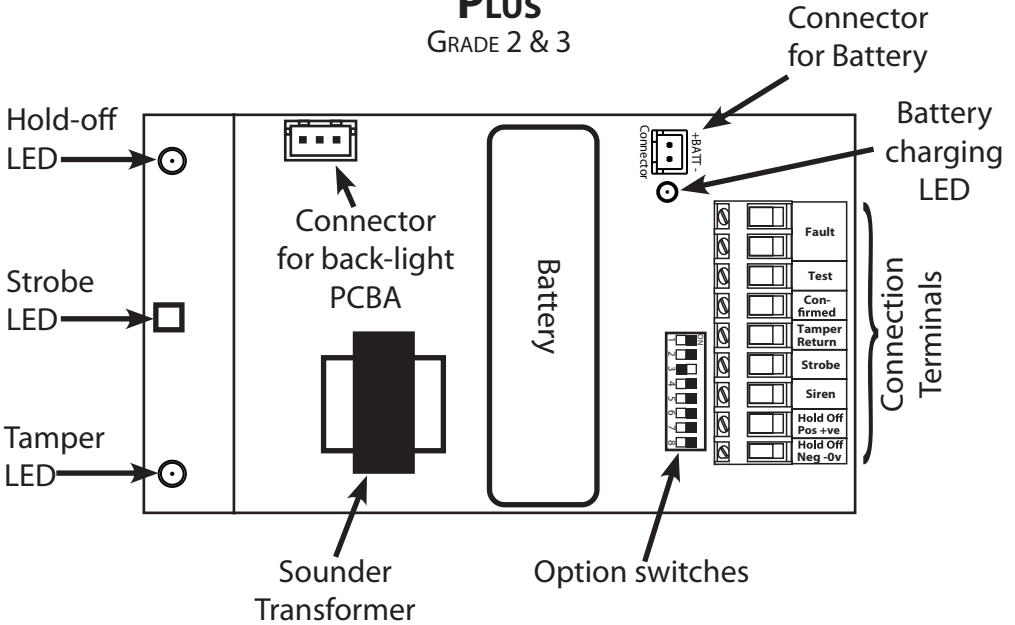

STANDARD GRADE 2 ONLY

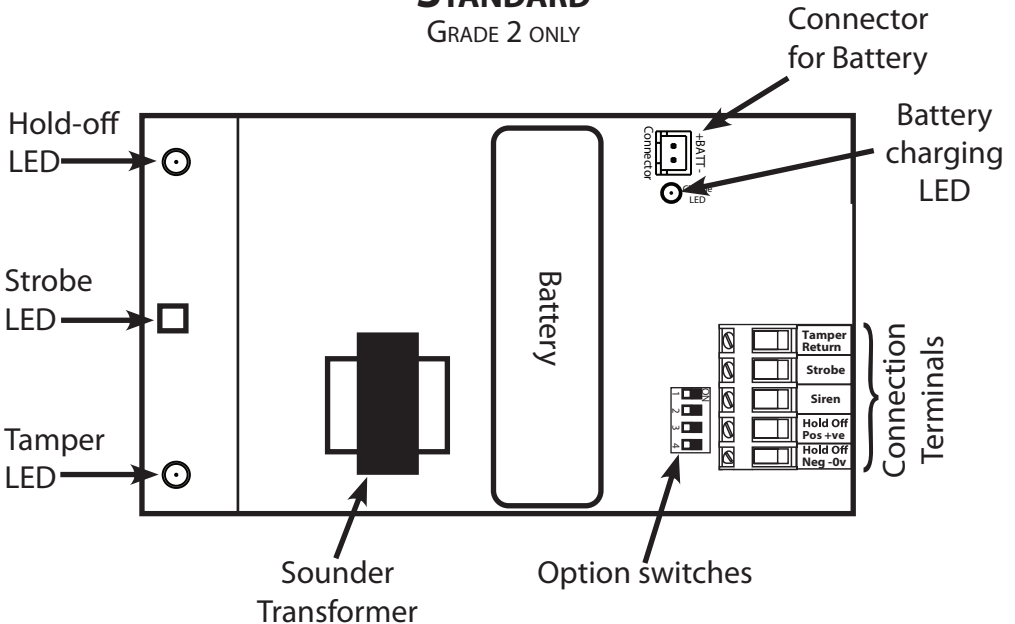

WIRE-FREE PCB LAYOUTS

WARNING DEVICE (WD)

GRADE 2 ONLY

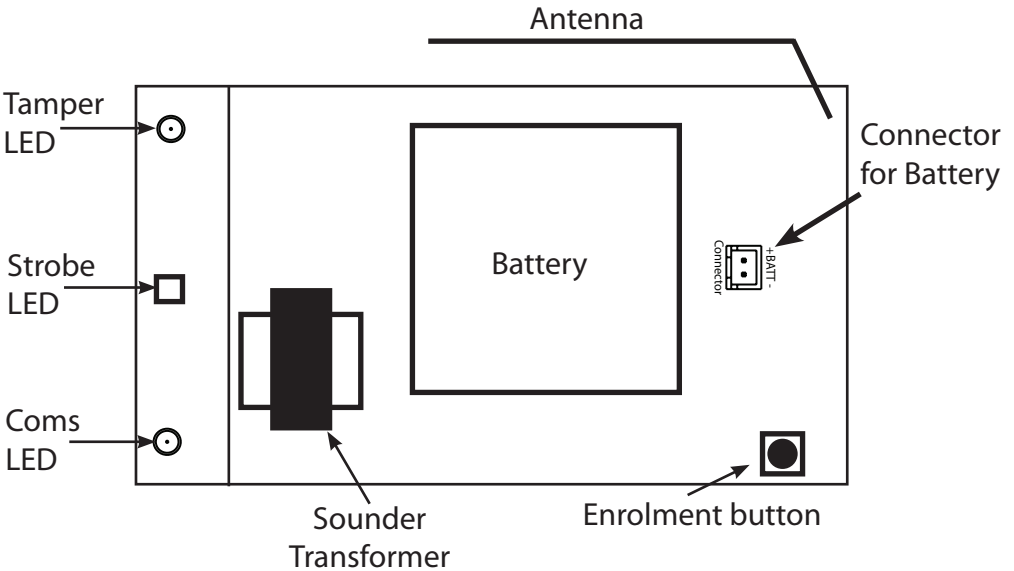

CONTROL PANEL MODULE (CPM)

GRADE 2 ONLY

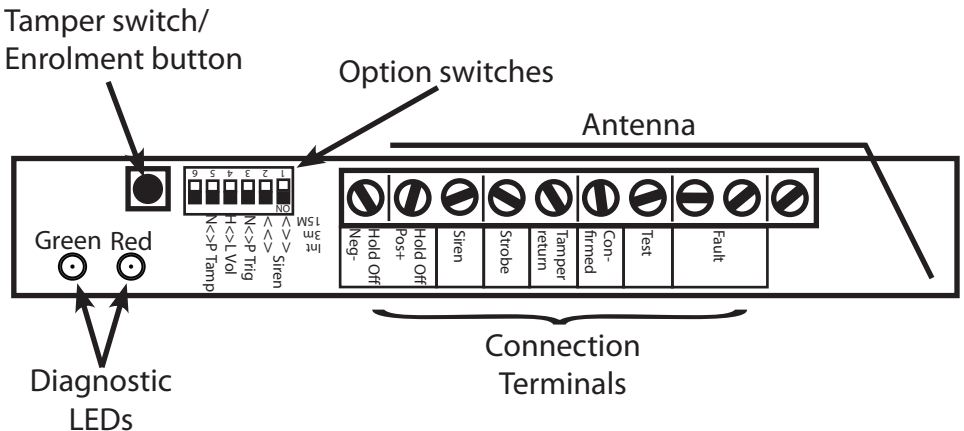

TERMINAL DESCRIPTION

Model	Terminal Number	Terminal Name	Description
PLUS & CPM	9	Fault	These 2 terminals are normally closed, going open when a fault is detected. They also act as a confirmation that the test routine has started by opening and closing after a successful completion of the test routine.
PLUS & CPM	8	Fault	
PLUS & CPM	7	Test	A Positive signal from the control panel to start the test routine LED
PLUS & CPM	6	Confirmed	A Negative signal from the control panel to change the Sounder and Strobe pattern
PLUS, STANDARD & CPM	5	Tamper Return	A signal from the SENZA to the control panel to indicate the condition of the tamper circuit
PLUS, STANDARD & CPM	4	Strobe	A signal from the control panel to activate the strobe LED
PLUS, STANDARD & CPM	3	Siren	A signal from the control panel to activate the siren LED
PLUS, STANDARD & CPM	2	Hold-off Positive +ve	A permanent positive DC supply from the control panel
PLUS, STANDARD & CPM	1	Hold-off Negative 0v	A permanent negative DC supply from the control panel

DIP SWITCH SETTINGS

PLUS MODELS

1	2	3	4	5	6	7 & 8
Back-light	Tamp Rtn	SAB/SCB	Volume	Trigger signal	Trigger Mon	Siren Cut-off timings
<input type="checkbox"/> ON <input type="checkbox"/> ECO	<input type="checkbox"/> Pos <input type="checkbox"/> Neg	<input type="checkbox"/> SAB <input type="checkbox"/> SCB	<input type="checkbox"/> Lo <input type="checkbox"/> Hi	<input type="checkbox"/> Pos <input type="checkbox"/> Neg	<input type="checkbox"/> ON <input type="checkbox"/> OFF	<input type="checkbox"/> 15 <input type="checkbox"/> 3 <input type="checkbox"/> Int

Default setting

ON							
<input type="checkbox"/>	<input type="checkbox"/>	<input type="checkbox"/>	<input type="checkbox"/>	<input type="checkbox"/>	<input type="checkbox"/>	<input type="checkbox"/>	<input type="checkbox"/>
1	2	3	4	5	6	7	8

STANDARD MODELS

1	2	3	4
Trigger signal	Volume	Siren Timing	Not Used
<input type="checkbox"/> Pos <input type="checkbox"/> Neg	<input type="checkbox"/> Lo <input type="checkbox"/> Hi	<input type="checkbox"/> Int <input type="checkbox"/> 15	

Default setting

ON			
<input type="checkbox"/>	<input type="checkbox"/>	<input type="checkbox"/>	<input type="checkbox"/>
1	2	3	4

WIRE-FREE MODEL

1 & 2	3	4	5	6
Siren Cut-off timings	Trigger signal	Volume	Tamper Rtn	Not Used
<input type="checkbox"/> 15 <input type="checkbox"/> 3 <input type="checkbox"/> Int	<input type="checkbox"/> Pos <input type="checkbox"/> Neg	<input type="checkbox"/> Lo <input type="checkbox"/> Hi	<input type="checkbox"/> Pos <input type="checkbox"/> Neg	

Default setting

ON					
<input type="checkbox"/>	<input type="checkbox"/>	<input type="checkbox"/>	<input type="checkbox"/>	<input type="checkbox"/>	<input type="checkbox"/>
1	2	3	4	5	6

MOUNTING INSTRUCTIONS

Identify a suitable mounting location for the warning device on a flat wall. If you are installing the Wirefree version, you can use the built-in coms feature to locate the best location and ensure there is communication between the warning device and the control panel module.

It should not be possible to reach the device without the aid of access equipment, where practical it should be sited under the eaves to give additional protection.

Mark the fixing points on the surface of the selected location using the drill template on the back of the box. Drill 3 holes using a 5.5mm masonry drill 41mm deep for the enclosed wall plugs, insert the wall plugs into the holes, fit the top centre screw, enclosed, leaving it protruding by 25mm.

Feed the cable through the cable entry point on the SENZA and carefully slot the top fixing point of the SENZA over the previously installed screw, rotate the 2 x bottom fixing points, if necessary, to allow the holes to line up and fix in-place using the enclosed screws.

Please note in order for the tamper protection to function correctly one of the mounting screws is required to be fitted in the removal from wall mechanism as shown below. Do not over-tighten this screw. If forced removal is attempted this will cause irreversible damage and may need replacing.

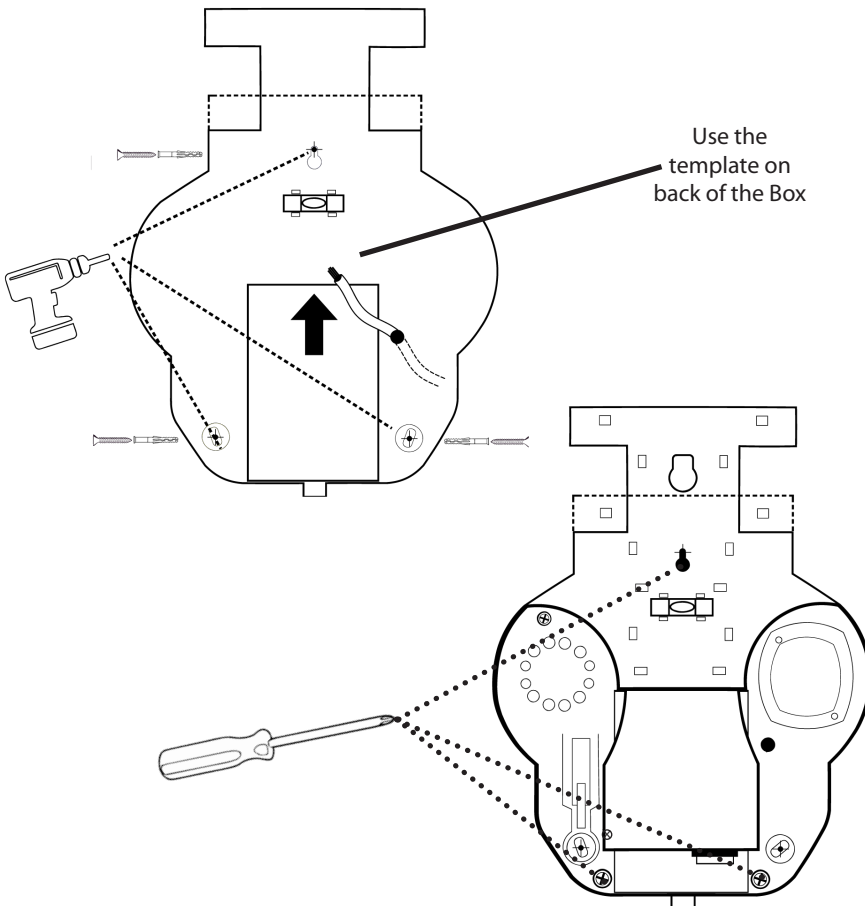

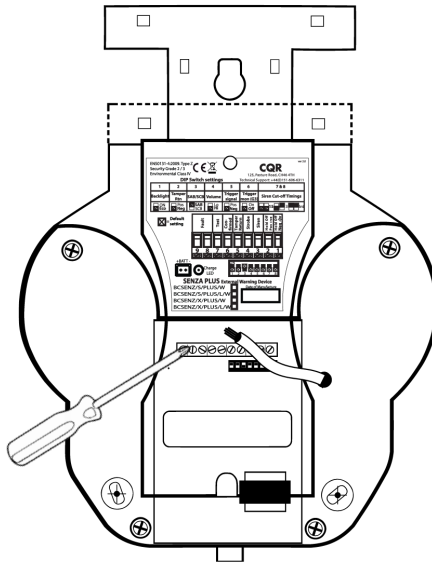

MOUNTING INSTRUCTIONS CONTROL PANEL MODEL (CPM)

When identifying a suitable mounting location for the CPM, the following points should be noted:

- Do not mount next to an AC source
- Mount away from wireless interference sources (computers, cordless phones, wireless routers, etc.)
- Large metal objects (a distance of 1m is recommended)

Temporarily place the unit in the selected location (do not hold) ensuring that the CPM is **vertical**, using the built-in coms feature in the warning device, ensure that there is communication between the warning device and the CPM see page 12, if not move the location of the CPM and repeat the process.

Mount the CPM in the selected location, connect the CPM to the control panel as shown on page 12.

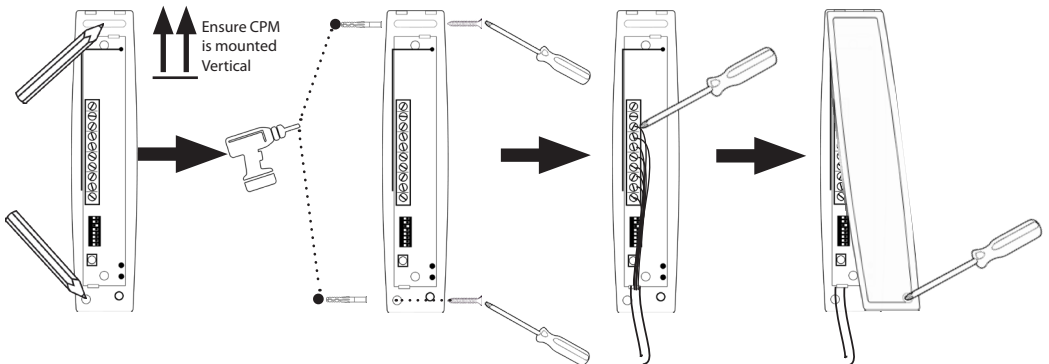

WIRING CONNECTION GUIDE

Standard Version

1. Ensure that the DIP switches are set to your requirements.
2. Connect the wires to the SENZA as shown below.
3. Plug in the battery and one bleep will be heard.
4. Ensure the tamper switch will close properly and fit the lid, two bleeps will be heard.
5. The tamper LED should start to flash twice a second.
6. This will stay like this until hold off voltage is applied or the battery goes flat.
7. Connect the control panel as indicated below.
8. Apply power to the SENZA.
9. Both the hold-off LED and the tamper LED will now flash. Two bleeps will be heard.
10. After a few seconds the unit will bleep again and the LED's will flash alternately.
11. After 5 minutes the engineer mode will expire and the LED's will flash at the normal rate of once per second.
12. The SENZA is now in its normal mode.

Note:- Examples shown below are provided only as a guide, Control panel manufacturers may alter their notation from time to time and there may be differences to those shown.

SENZA CONNECTIONS

5	4	3	2	1
Tamper Rtn	Strobe	Siren	Hold-off Pos +	Hold-off Neg -

<ol style="list-style-type: none"> 1. Connect Hold-off Neg - 0v to D 2. Connect Hold-off Pos + ve to A 3. Connect Siren to B 4. Connect Strobe to S 5. Connect Tamper Return to C 	Texcom	C	S	B	A	D
--	---------------	---	---	---	---	---

<ol style="list-style-type: none"> 1. Connect Hold-off Neg - 0v to 12v com 2. Connect Hold-off Pos + ve to +12v 3. Connect Siren to BELL 4. Connect Strobe to STRB 5. Connect Tamper Return via a 2K2Ω resistor to D1 	Pyronix	D1	STRB	BELL	+12V	COM
--	----------------	----	------	------	------	-----

<ol style="list-style-type: none"> 1. Connect Hold-off Neg - 0v to 0v 2. Connect Hold-off Pos + ve to 12v 3. Connect Siren to Bell 4. Connect Strobe to STB 5. Connect Tamper Return to TR 	Scantronic	TR	STB	BELL	+12V	0v
---	-------------------	----	-----	------	------	----

<ol style="list-style-type: none"> 1. Connect Hold-off Neg - 0v to 12v - 2. Connect Hold-off Pos + ve to 12v + 3. Connect Siren to OP BELL 4. Connect Strobe to OP Strobe 5. Connect Tamper Return to an input via a 2K2Ω resistor 	Honeywell Input	Input	OP STRB	OP BELL	12V	12v-
---	------------------------	-------	---------	---------	-----	------

WIRING CONNECTION GUIDE

PLUS Version

1. Ensure that the DIP switches are set to your requirements.
2. Connect the wires to the SENZA as shown below.
3. Plug in the battery and one bleep will be heard.
4. Ensure the tamper switch will close properly and fit the lid, two bleeps will be heard.
5. The tamper LED should start to flash twice a second.
6. This will stay like this until hold off voltage is applied or the battery goes flat.
7. Connect the control panel as indicated below.
8. If Trigger wire monitoring is selected the 2 x 1kΩ resistors must be fitted prior to power up (G3 requirement).
9. Apply power to the SENZA.
10. Both the hold-off LED and the tamper LED will now flash. Two bleeps will be heard.
11. After a few seconds the unit will bleep again and the LED's will flash alternately.
12. After 5 minutes the engineer mode will expire and the LED's will flash at the normal rate of once per second.
13. The SENZA is now in its normal mode.

Note:- Examples shown below are provided only as a guide, Control panel manufacturers may alter their notation from time to time and there may be differences to those shown.

SENZA CONNECTIONS

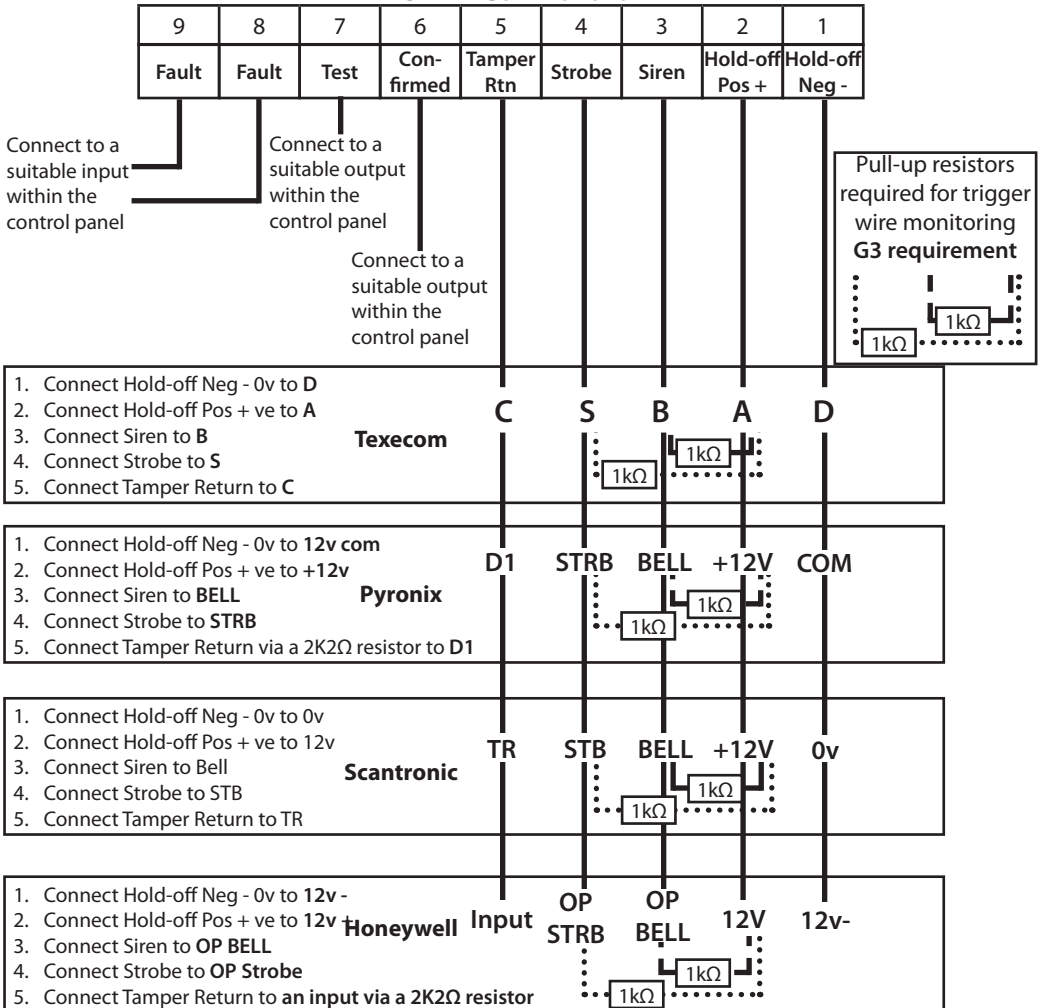

WIRING CONNECTION GUIDE

Wirefree Version

1. Connect the **CPM** to the control panel as shown in the *'Senza CPM connections'* below, ensuring that the DIP switches are set to your requirements. The Green and Red LEDs should flash alternately.
2. Connect the battery in the **WD**. The **CPM** and **WD** should automatically pair. This is indicated by the Green LED on the **WD** flashing every 2 seconds. If not refer to Installation and operating instructions on *'How to pair'*.
3. During the next 30 minutes the **WD** will be in engineer mode, after which it will automatically leave this mode.
Note: if the tamper is still open the sounder will sound.
4. Whilst the **WD** is in engineer mode the Green LED flashes every 2 seconds to indicate that the **WD** is communicating with the **CPM**.
5. Using this feature will allow you to select the best position for the **WD** to be installed, if the Green LED stops flashing it has lost communication with the **CPM** and should be repositioned.
6. The Blue LED on the **WD** flashing every 2 seconds indicates that the tamper is closed.
7. To exit Engineer mode briefly apply a trigger to the Siren input of the **CPM** the Strobe will flash once and the sounder will chirp.
8. Normal operating mode is indicated by the Green and Blue LEDs on the **WD** flashing alternately every 4 seconds.

Note:- Examples shown below are provided only as a guide, Control panel manufacturers may alter their notation from time to time and there may be differences to those shown.

CPM Connections

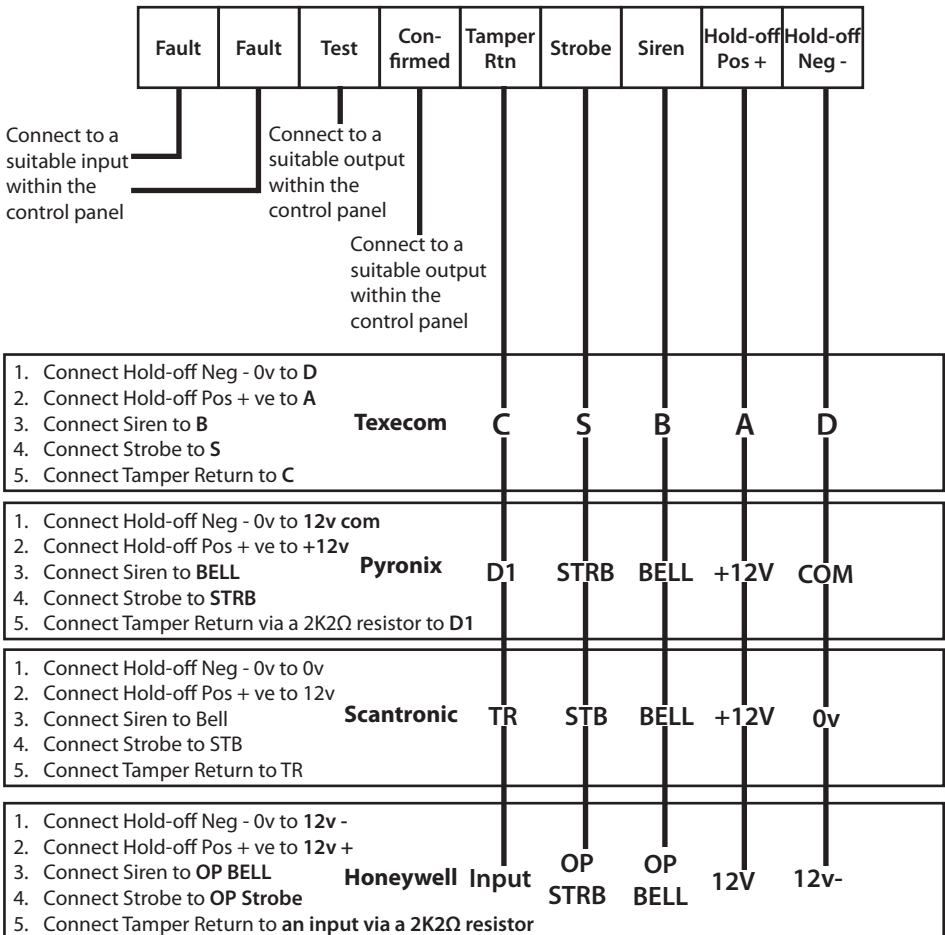

FITTING COVERS

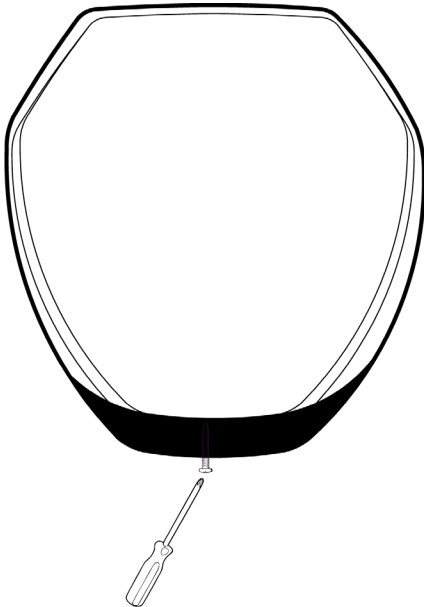
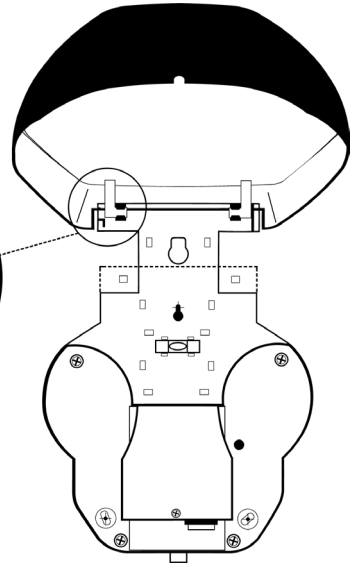
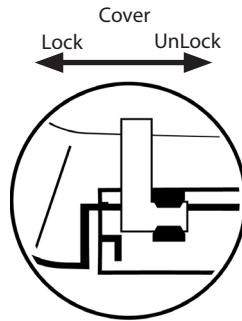
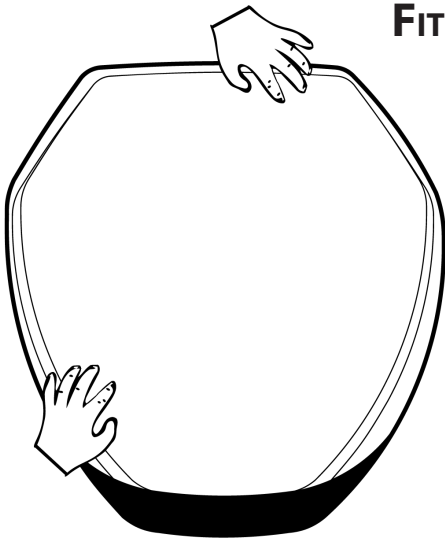

OPERATING INSTRUCTIONS

WIRED MODELS

Please refer to the DIP switch setting on page 7 to setup the device for the configuration you require.

To activate the siren apply an appropriate signal (depending on selection made via the DIP switch) to the SIREN terminal (3). To deactivate the siren remove the applied signal.

To activate the strobe apply an appropriate signal (depending on selection made via the DIP switch) to the STROBE terminal (4). To deactivate the strobe remove the applied signal.

During an activation of the Siren and/or Strobe, if a negative signal is applied to the Confirmed Terminal (6) it will change the Siren tone and/or the Strobe flash rate. Removal of the signal will result in the Siren tone and/or the Strobe flash rate returning to it normal tone/rate.

If the device's tamper protection is activated by opening the cover or by forcibly removing the warning device from the wall, the signal (depending on the selection made via DIP switch) will be removed from the Tamper Return terminal (5). Closing the cover will result in the signal being restored.

Note: The Senza is designed not to sound when the tamper switch is opened to allow for the installation/service engineer to access the unit without generating a sound, however this will depend on the condition/settings of the control panel it is connected to e.g if the panel is in a set condition the sounder may sound.

If a positive signal is applied to the Test input (7) it will start the test routine.

If the rechargeable battery is disconnected from the device or is not capable of supplying power to the device, then the Fault output circuit will open.

The loss of the remote power source to the device will activate the siren for the pre selected time via DIP switches 7 & 8 on the PLUS or DIP switch 3 on the STANDARD.

The GREEN (tamper) and RED (hold-off) comfort LEDs flash alternately at 1Hz. If the GREEN LED stops flashing this indicates that the tamper protection for the cover and/or the removal from wall is open. If the RED LED stops flashing this indicates that there is no voltage on the Hold-off terminals.

The Red battery LED is illuminated when the battery is healthy. If the LED is extinguished this indicates that the battery is disconnected or faulty.

WIRE-FREE MODEL

Please refer to the DIP switch setting on page 7 to setup the device for the configuration you required.

To activate the siren apply an appropriate signal (depending on selection made via the DIP switch) to the SIREN terminal. To deactivate the siren remove the applied signal.

To activate the strobe apply an appropriate signal (depending on selection made via the DIP switch) to the STROBE terminal. To deactivate the strobe remove the applied signal.

During an activation of the siren and/or strobe, if a negative signal is applied to the Confirmed Terminal it will change the siren tone and or the strobe flash rate. Removal of the signal will result in the siren tone and/or the strobe flash rate returning to it normal tone/rate.

If the device's tamper protection is activated by opening the cover or by forcibly removing the warning device from the wall, the signal (depending on the selection made via DIP switch on the CPM) will be removed from the Tamper Return terminal and the sounder will sound. Closing the cover will result in the signal being restored and the sounder stopping.

If a positive signal is applied to the Test input it will start the test routine. Failure of the test routine will result in the fault output staying open.

The battery is monitored every 24hrs and this test checks the condition of the battery by applying a load to the battery. If the battery fails this test the fault output will open circuit.

The GREEN (coms) and BLUE (tamper) comfort LEDs flash alternately every 5 seconds. If the BLUE LED stops flashing this indicates that the tamper protection for the cover and/or the removal from wall is open. If the GREEN LED stops flashing this indicates that there is no communication with the control panel module.

SPECIFICATION

WIRED

Hold off voltage:	10-15 vDC (12 vDC nominal)	
Current Consumption @ 12 vDC:	SAB Mode	SCB mode
Quiescent:	~35mA (battery fully charged)	~35mA (battery fully charged)
Back-light ON	~55mA	~55mA
Alarm (Sounder & Strobe):	~300mA	~120mA
Siren:	~175mA	~110mA
Strobe:	~55mA	~55mA
Sounder:	Piezo	
Type:	Tone	
Acoustic Output:	≤ 15 minutes, ≤ 3 minutes or intermittent	
Sound duration:	~105db(A) @ 1 metre	
Sound Output Levels:	-ve applied, +ve applied	
Triggering Method:	LED	
Strobe:	~ 60 per minute	
Type:	~ 7 per minute	
Flash Rate:	-ve applied, +ve applied	
Strobe saver mode:	Lithium Ion (rechargeable)	
Triggering Method:	3.7 volt	
Battery:	2000mAh	
Type:	Tamper (GREEN), Hold-off (RED) and Battery charging (RED)	
Nominal Voltage:	Removal from mounting and cover.	
Capacity:		
LED Indicators:		
Tamper Detection:		
STANDARDS:	Security Grade: 2/3, Environmental Class: IV	
EN50131-1: 2006 + A3: 2020	Warning device Type: Z	
EN50131-4: 2019		

WIRE-FREE

WARNING DEVICE (WD)	Lithium Manganese Dioxide (non-rechargeable)	
Battery:	3 volt	
Type:	4700mAh	
Nominal Voltage:	~2 years (depending on the number and duration of activations)	
Capacity:		
Approximate life:		
Current Consumption:	~3.5mA	
Quiescent:	~245mA	
Alarm (Sounder & Strobe):	Piezo	
Sounder:	Tone	
Type:	≤ 15 minutes, ≤ 3 minutes or intermittent	
Acoustic Output:	~105db(A) @ 1 metre	
Sound duration:	LED	
Sound Output Levels:	~ 60 per minute	
Strobe:	~ 7 per minute	
Type:	Tamper (BLUE), Comms (GREEN)	
Flash Rate:	Removal from mounting and cover.	
Strobe saver mode:	868MHz Narrowband	
LED Indicators:	100m (Line of Site)	
Tamper Detection:		
Radio Frequency:		
Communication Distance:		
CONTROL PANEL MODULE (CPM)	10-15vDC (12vDC nominal)	
Power supply:		
Current Consumption @12vDC:	~20mA	
Quiescent:	~30mA	
Alarm (Sounder & Strobe):	RED & GREEN used for diagnostics	
LED indicators:	Cover and Removal from mounting	
Tamper Detection:		
STANDARDS:	Security Grade 2, Environmental Class II(CPM) IV(WD)	
EN50131-1:2006 + A3:2020;	Type W	
EN50131-4:2019;	Grade 2	
EN50131-5-3:2017;		

SAFETY PRECAUTIONS

Never remove the cover when the strobe is flashing.

The piezo transformer will be hot during and after sounding. Whilst not directly hazardous, touching it when hot will cause discomfort and should be avoided.

When the Senza is in an alarm condition, high voltages are present. Before removing the cover, stop the piezo and strobe from operating.

Failure to observe the following precautions regarding the batteries could lead to danger of heating, ignition, explosion and leaking of hazardous chemicals.

- Do not throw into a fire
- Do not heat
- Do not overcharge
- Do not reverse charge
- Do not attempt to charge the battery used in the wire-free version as it is not rechargeable
- Do not short circuit the battery wires
- Do not disassemble

Always observe local regulations when disposing of a battery.

Plastic bags can suffocate, always dispose of packaging carefully.



PRODUCT ORDER CODES

Order code	Description
BCSENZ/S/STD/W	Senza S Grade 2 Backplate White
BCSENZ/S/PLUS/W	Senza S Grade 2/3 Backplate White
BCSENZ/S/PLUS/L/W	Senza S Grade 2/3 Backplate White with Backlight
BCSENZ/S/WF/W	Senza S Wirefree Kit White (WD & CPM)
BCSENZ/S/COV/W/B	Senza S Cover White with Blue Lens
BCSENZ/S/COV/W/B/L	Senza S Cover White with Blue Lens with Backlight Panel
BCSENZ/S/DUM/WH	Senza S Dummy Backplate White
BCSENZ/X/STD/W	Senza X Grade 2 Backplate White
BCSENZ/X/PLUS/W	Senza X Grade 2/3 Backplate White
BCSENZ/X/PLUS/L/W	Senza X Grade 2/3 backplate White with Backlight
BCSENZ/X/WF/W	Senza X Wirefree Kit (WD & CPM)
BCSENZ/X/COV/W	Senza X Cover White
BCSENZ/X/COV/W/L	Senza X Cover White with Backlight Panel
BCSENZ/X/DUM/W	Senza X Dummy Backplate
BCSENZ/S/WF/WD/W	Senza S Wirefree Warning device Backplate (WD)
BCSENZ/X/WF/WD/W	Senza X Wirefree Warning device Backplate (WD)
BCSENZ/WF/CPM/WH	Senza Wirefree Control Panel Module White (CPM)